



881

CONVERSION PACKET

**FOR ARISTO-CRAFT®
HEAVYWEIGHT
PASSENGER CARS**

When properly installed on cars, the parts in this packet will improve the performance of the Aristo-Craft® heavyweight passenger cars and simplify the mounting of Kadee® Nos. 819 and 838 coupler packets on these cars. Please read instructions thoroughly before proceeding.

The following tools are required for this installation:

- small saw (jeweler's or hobby)
- small screwdrivers (flat and phillips)
- X-acto® knife
- small file
- super glue (Cyanoacrylate)
- soldering iron (optional)
- 4-40 tap (optional)

This packet should include:

- 2 ea. mounting shims
- 4 ea. shim rails
- 4 ea. washers
- 2 ea. bushings

Additional clearance is needed between the trucks and the car body. This is corrected by placing the supplied washers under the truck on the pivot post and stop post. Remove the two screws which hold the truck in place (Fig.1). Lift the truck so that you can slip one washer on the pivot post and stop post, then replace the truck. One of the supplied bushings is used on the rear stop post screw when securing the truck. The front screw should not be over tightened or the truck will notivot properly.

Fig.1

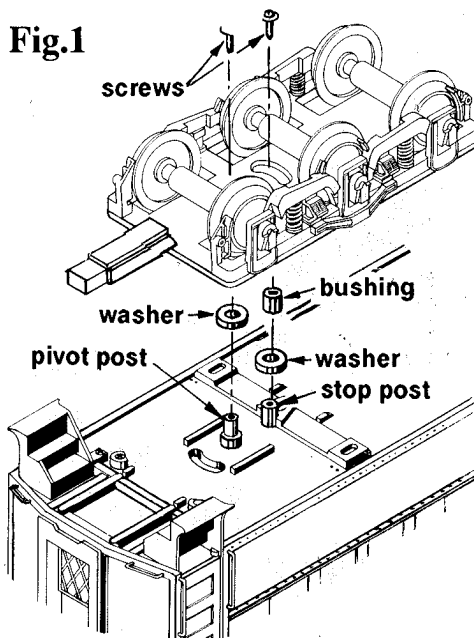

Some cars are equipped with truss rods which hang from the underbody (Fig.2). On small radius layouts these will interfere with the trucks and should be removed. Remove the screws holding the queenposts and carefully pry out the ends of the truss rods.

Fig.2

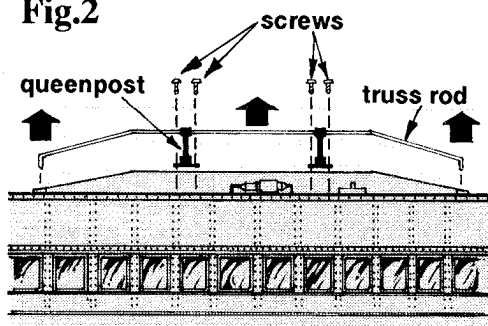

**MOUNTING KADEE
COUPLERS
WITH FLEX-BRACKETS**

The width of the wheels on the trucks are too narrow for the proper operation of Kadee® couplers. The car will not center itself on the track which may prevent proper coupling and uncoupling; also, the wheels will not clear an uncoupler which has been placed between the rails. The wheels should be widened to allow proper operation of the couplers as well as permitting the car to negotiate the desired radius. Each truck has three wheel sets. The end wheel sets can be widened to approximately 1.570" (19/16") between the wheels. The center wheel set should be 1/32" narrower so that the car will not bind on turns. To adjust the wheel width try the wheel set

out of the truck with your fingers (Fig.3). Pull on the wheels until one of the wheels pulls out of the plastic axle sleeve. The wheels can now be slipped back in the sleeve at the correct width and then re-installed in the truck. The wheel set should remain at this width but if it does change a small amount of glue can be used to secure it.

Fig.3

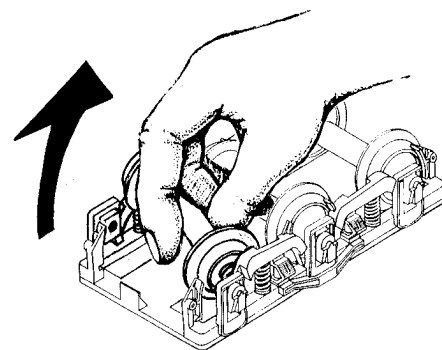

G-SCALE

1. For proper clearance you will need to cut the drawbar off of the truck as shown in (Fig.4). Remove the two screws which hold the truck in place. A soldering iron can be used to remove the black and red wires from the truck. This will allow the entire truck to be lifted out and easily cut. (Label the wires so that they can be properly resoldered.) If the truck is to be cut while still on the car, lift it up as high as the wires will allow and protect the car so that it will not be damaged by the saw. Remove any rough edges after cutting and re-install the truck.

Fig.4

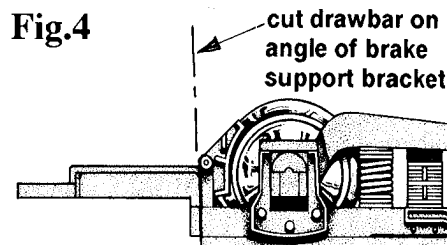

2. Cut the rear tab off of the flex bracket (Fig.5). Remove any rough edges.

Fig.5

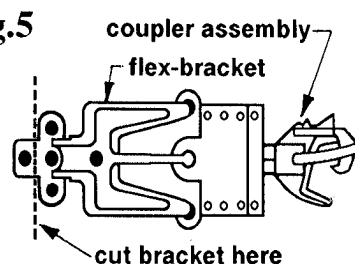

3. Tap the three mounting holes in the mounting shim with a 4-40 tap (Fig.6). If a tap is unavailable, the 4-40 screws will self-tap. It is easiest to tap from the bottom side. Tapping should be done as straight as possible.

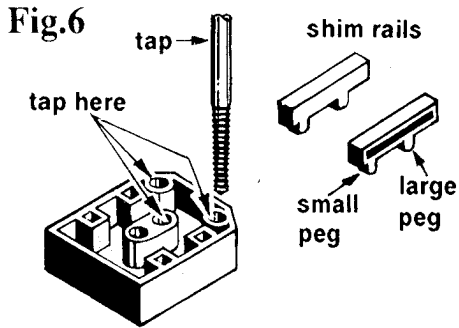

4. Cut the screws to the proper length as described in the flex bracket instructions. The coupler assembly with flex bracket can now be secured to the mounting shim using these screws. The front screw should not be over tightened (Fig.7).

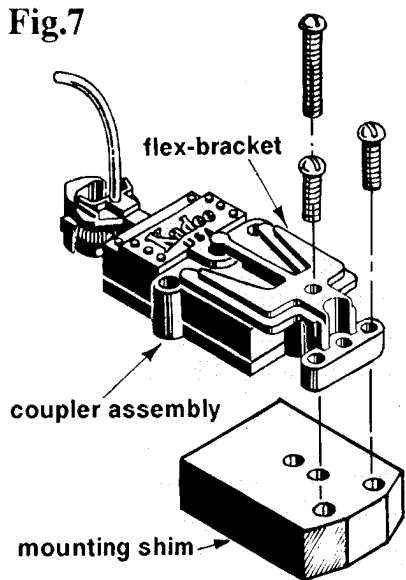

5. The mounting shim with coupler assembly is now glued into place on the car between the center sills (Fig.8). A better bond will result if you scrape the paint in the gluing area. For mounting on the rear of the Observation Car the supplied shim rails will be used. Glue the rails onto the mounting shim with the slotted side out. Note that there is a large peg and a small peg on the rail which will fit into the respective holes of the mounting shim (Fig.6). Scrape the paint in the gluing area and apply glue liberally. Make sure that the coupler is centered on the car (Fig.10).

Fig.8

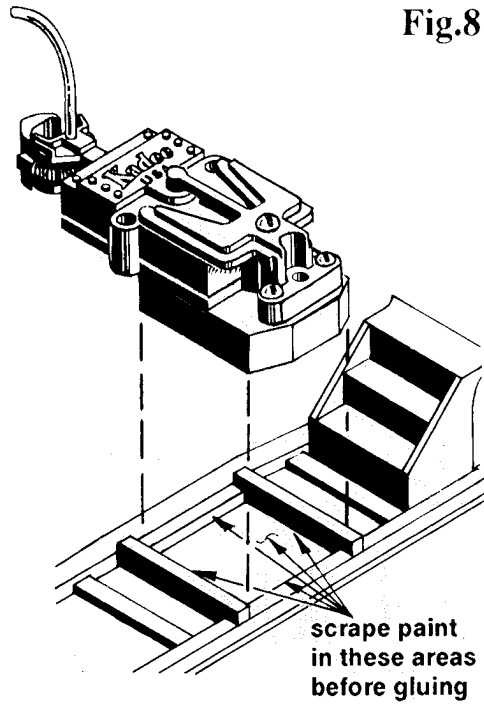

#1 SCALE

1. Installation is similar to G-scale with the added use of the shims and pivot pins supplied in the Kadee® No. 819 packet. The mounting shims are tapped and the 4-40 screws are cut to the proper length as described previously.
2. Cut the rear tab off of the flex bracket (Fig.5). Remove any rough edges.
3. A pivot pin is slipped into the gear box as in #6 of the flex bracket instructions. A shim is placed between the gear box and mounting shim before securing the coupler assembly with flex bracket to the mounting shim (Fig.9).

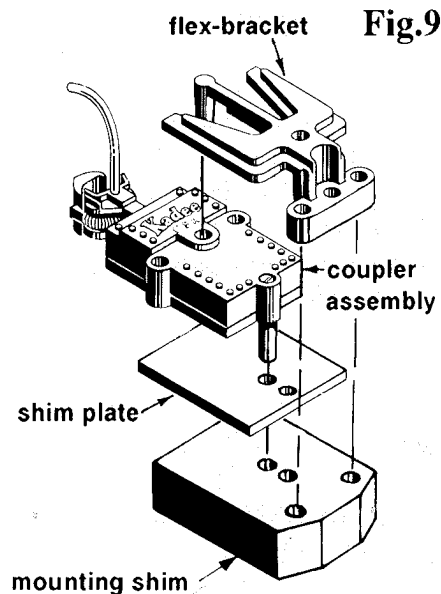

4. Secure the coupler assembly with flex bracket to the mounting shim using the 4-40 screws (Fig.7). The front screw should not be over tightened. If you notice interference between the flex bracket and the gear box refer to #10 of the flex bracket instructions.

5. The mounting shim with coupler assembly is now glued into place on the car as described in the previous G-scale instruction #5.

Fig.10

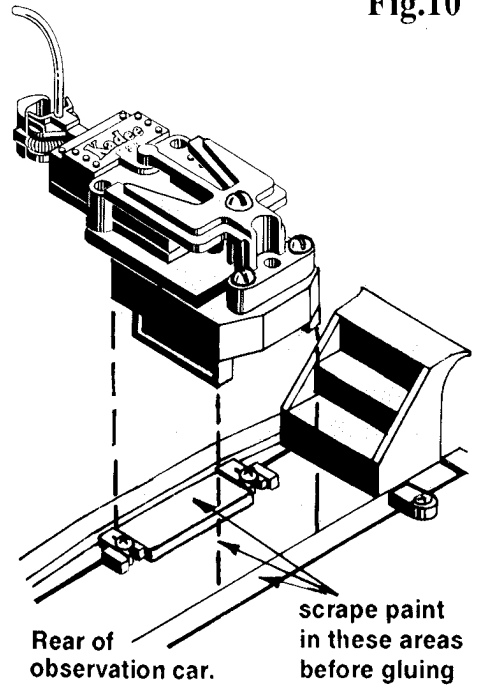

NOTE: Depending on the minimum radius of your layout you may need to cut the sides of the gear box back approximately 1/8" for added swing (Fig.11). Do not cut back too far or the coupler performance may be impaired.

Fig.11

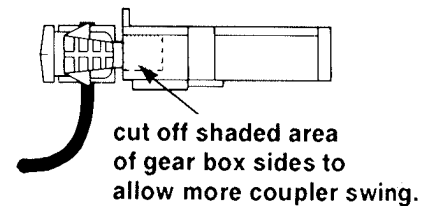

Kadee Quality products co.
 673 Avenue C
 White City, OR 97503 U.S.A.
The Coupler People